

PLAN VIEW

RH SHOWN - LH SIMILAR

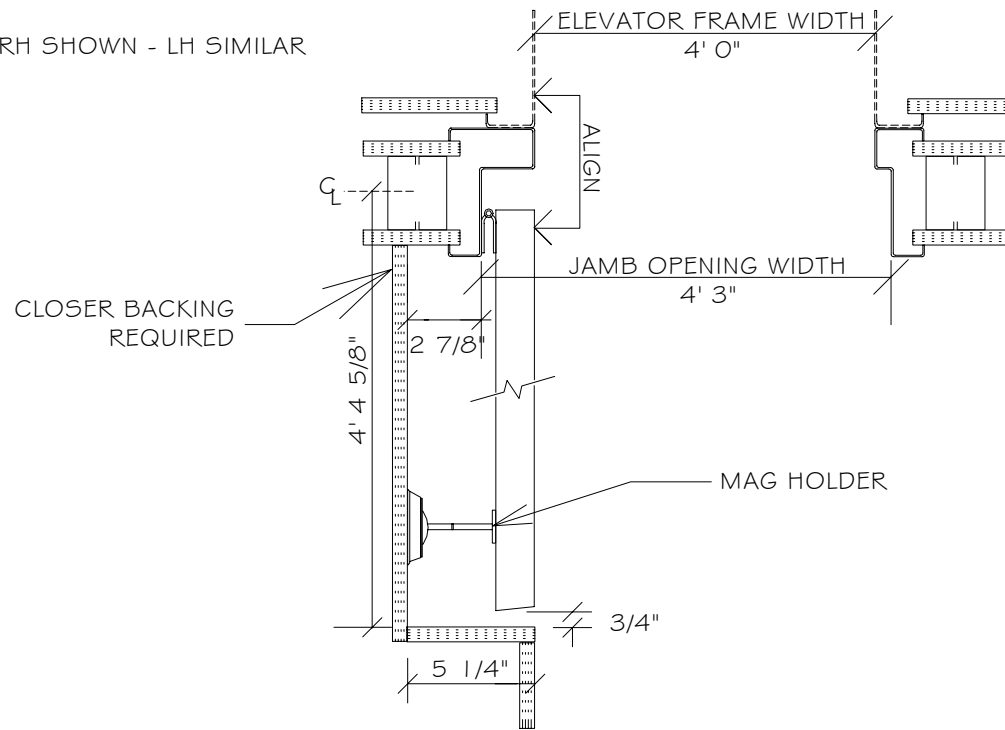

HEAD SECTION

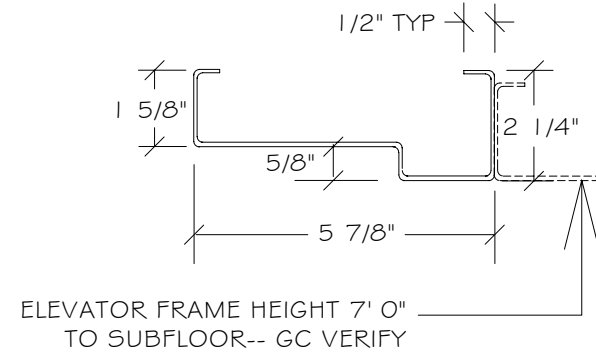

JAMB SECTION

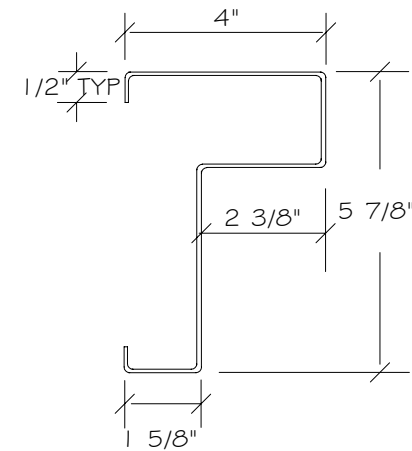

NOTE:

ALL DIMENSIONS PERTAINING TO POCKET WIDTH, DEPTH AND SOFFIT CLEARANCES ARE "NET TO FINISH". ALLOWANCES MUST BE MADE FOR WALL AND CEILING FINISHES, BASE BOARD, CROWN MOULDING, ETC.

INTERSTATE DOOR SALES, INC.

90° SINGLE HOLD OPEN DOOR  
IN FRONT OF 4' 0" WIDE ELEVATOR

DWG NO: EC905F-43

DATE: 08/10/06

SCALE: NONE

DRAWN BY: L. WALSH