

PLAN VIEW

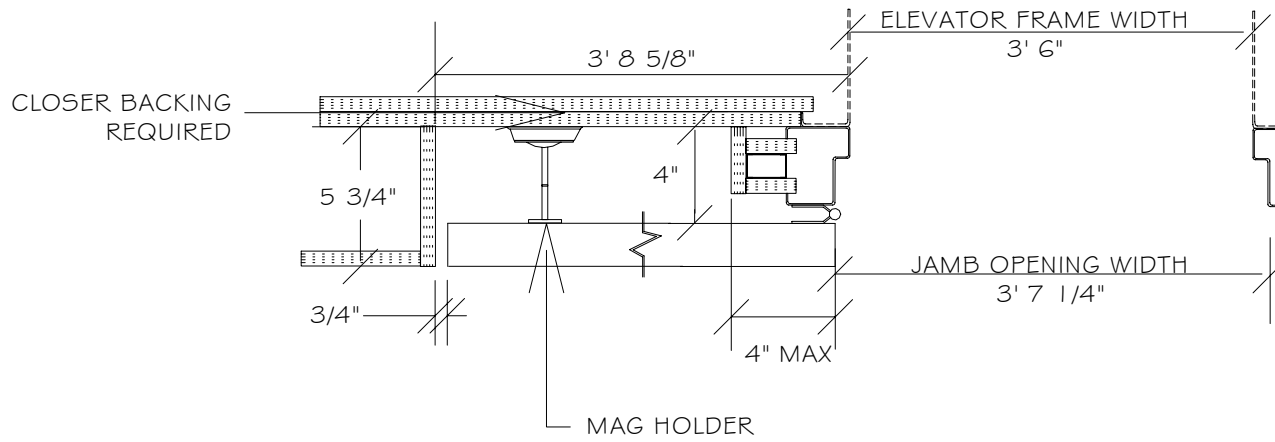

HEAD SECTION

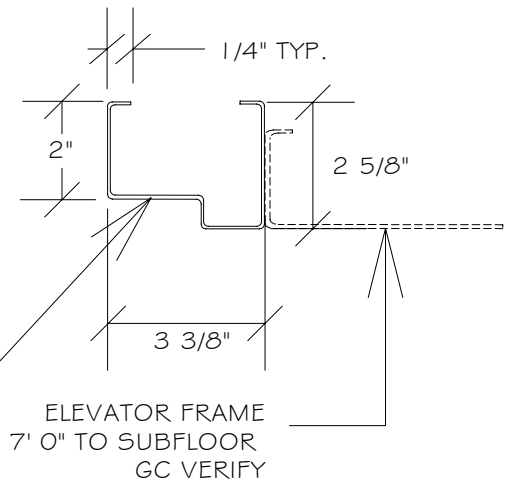

JAMB SECTION

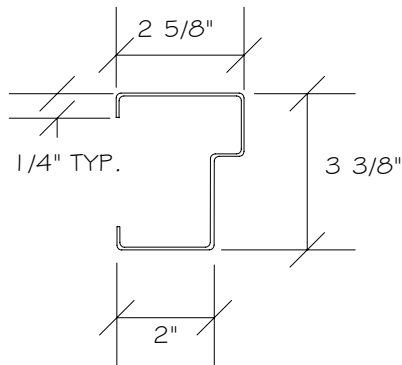

NOTE:
 ALL DIMENSIONS PERTAINING TO POCKET
 WIDTH, DEPTH AND SOFFIT CLEARANCES
 ARE "NET TO FINISH". ALLOWANCES MUST
 BE MADE FOR WALL AND CEILING FINISHES,
 BASE BOARD, CROWN MOULDING, ETC.

INTERSTATE DOOR SALES, INC.

1 80° SINGLE HOLD OPEN DOOR
 IN FRONT OF 3' 6" WIDE ELEVATOR

DWG NO: EC180S-37

DATE: 08/10/06

SCALE: NONE

DRAWN BY: L. WALSH