

PLAN VIEW

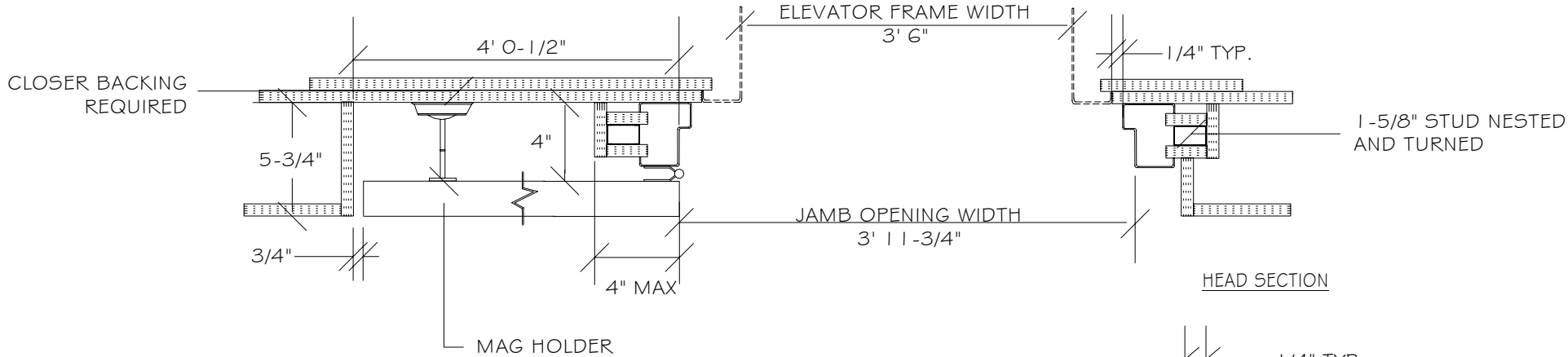

RH SHOWN - LH SIMILAR

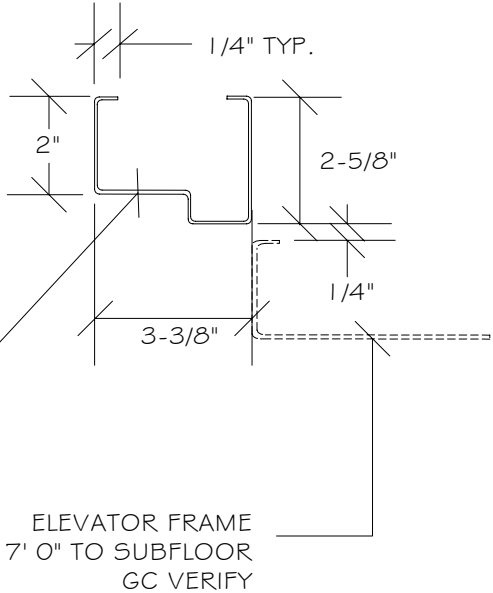
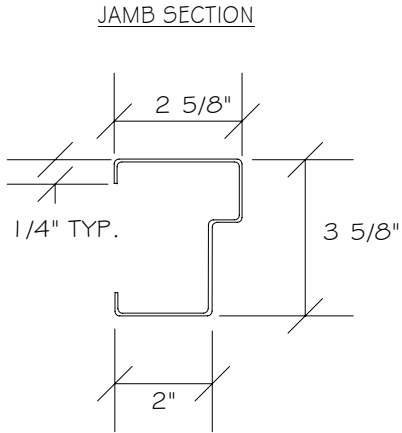

NOTE:
 ALL DIMENSIONS PERTAINING TO POCKET
 WIDTH, DEPTH AND SOFFIT CLEARANCES
 ARE "NET TO FINISH". ALLOWANCES MUST
 BE MADE FOR WALL AND CEILING FINISHES,
 BASE BOARD, CROWN MOULDING, ETC.

INTERSTATE DOOR SALES, INC.	
1 80° SINGLE HOLD OPEN DOOR SURROUNDING 3' 6" WIDE ELEVATOR	
DWG NO: EC1805-311	DATE: 08/10/06
SCALE: NONE	DRAWN BY: L. WALSH