

PLAN VIEW

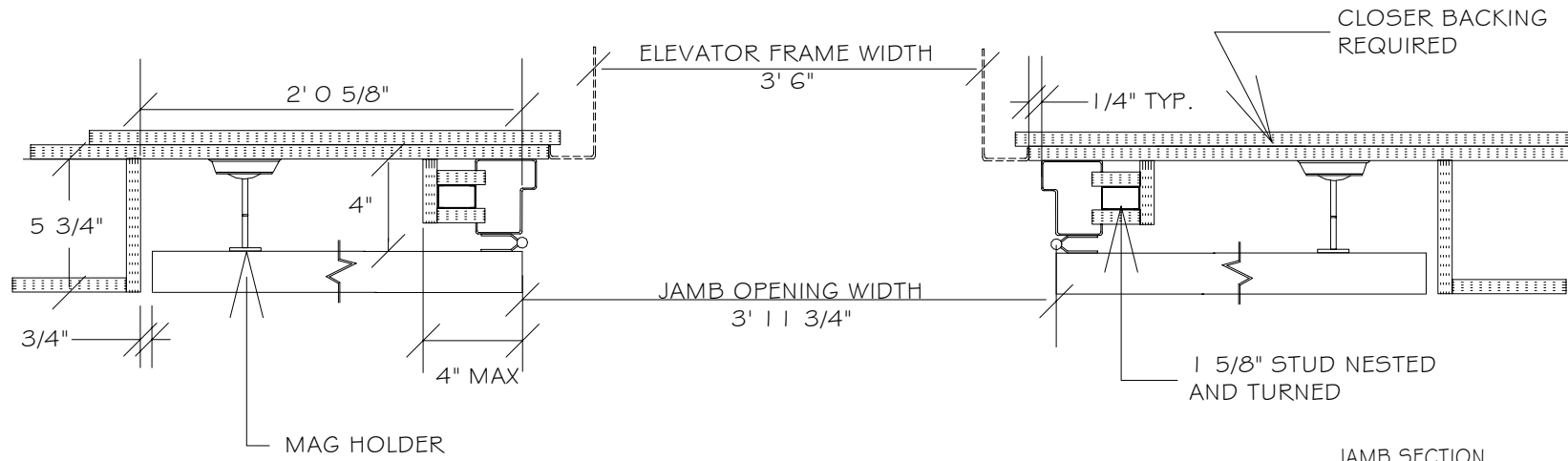

JAMB SECTION

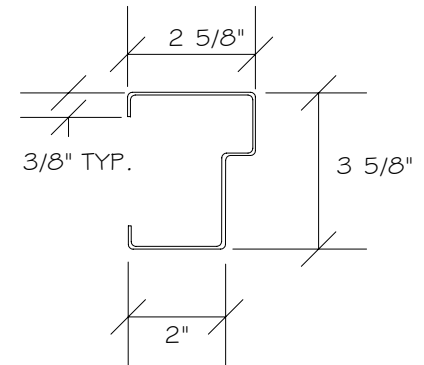

HEAD SECTION

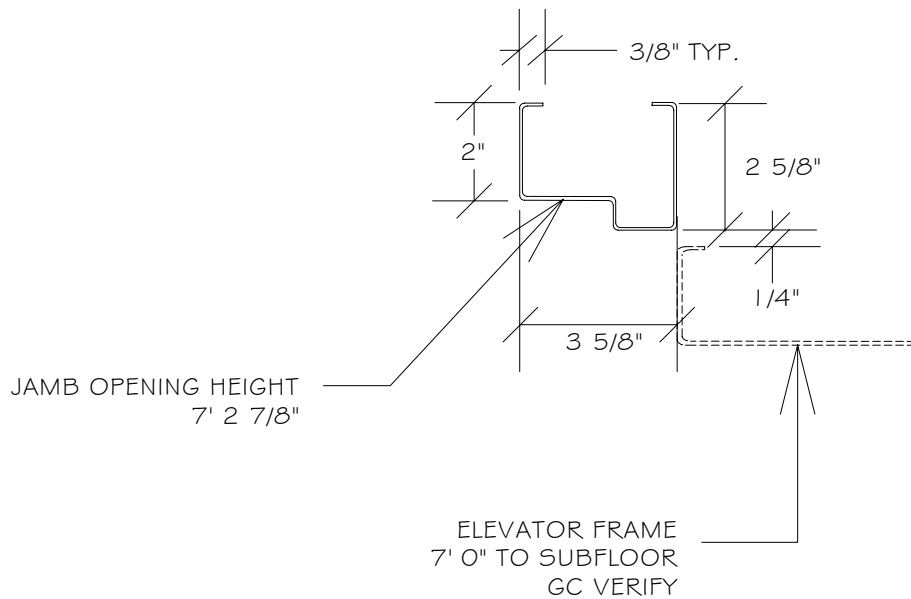

NOTE:
ALL DIMENSIONS PERTAINING TO POCKET WIDTH, DEPTH AND SOFFIT CLEARANCES ARE "NET TO FINISH". ALLOWANCES MUST BE MADE FOR WALL AND CEILING FINISHES, BASE BOARD, CROWN MOULDING, ETC.

| | |
|---|--------------------|
| INTERSTATE DOOR SALES, INC. | |
| 1 80° PAIR HOLD OPEN DOORS IN FRONT OF 3' 6" WIDE ELEVATOR | |
| DWG NO: OSHPD-P90PH | DATE: 08/10/06 |
| SCALE: NONE | DRAWN BY: L. WALSH |